

Magnescape®

デジタルゲージ / 數位測量器 / 数字測量器 /

Digital Gauge / Digitale Messtaster

**DK812SAR / DK812SAR5 /
DK812SALR / DK812SALR5 /
DK805SAR / DK805SAR5 /
DK805SALR / DK805SALR5 /
DK812SBR / DK812SBR5 /
DK812SBLR / DK812SBLR5 /
DK805SBR / DK805SBR5 /
DK805SBLR / DK805SBLR5**

お買い上げいただき、ありがとうございます。

ご使用前に、この取扱説明書を必ずお読みください。

ご使用に際しては、この取扱説明書どおりお使いください。

お読みになった後は、後日お役に立つこともございますので、必ず保管してください。

使用前請仔細閱讀說明書中的所有說明，並嚴格遵守這些說明。

請保留說明書以便將來參考。

感谢您惠购本产品。

使用之前请务必认真阅读本手册，并且严格按照手册中的规定操作。

将此手册留作以后的参考。

Read all the instructions in the manual carefully before use and strictly follow them.

Keep the manual for future references.

Lesen Sie die ganze Anleitung vor dem Betrieb aufmerksam durch und folgen Sie beim Betrieb des Geräts den Anweisungen. Bewahren Sie diese Bedienungsanleitung zum späteren Nachlesen griffbereit auf.

取扱説明書 / 使用説明書 / 使用说明书 /
Instruction Manual / Bedienungsanleitung

[For U.S.A. and Canada]

THIS CLASS A DIGITAL DEVICE COMPLIES WITH PART 15 OF THE FCC RULES AND THE CANADIAN ICES-003. OPERATION IS SUBJECT TO THE FOLLOWING TWO CONDITIONS.

- (1) THIS DEVICE MAY NOT CAUSE HARMFUL INTERFERENCE, AND
- (2) THIS DEVICE MUST ACCEPT ANY INTERFERENCE RECEIVED, INCLUDING INTERFERENCE THAT MAY CAUSE UNDERSIGNED OPERATION.

CET APPAREIL NUMÉRIQUE DE LA CLASSE A EST CONFORME À LA NORME NMB-003 DU CANADA.

このマニュアルに記載されている事柄の著作権は当社にあり、説明内容は機器購入者の使用を目的としています。

したがって、当社の許可なしに無断で複写したり、説明内容（操作、保守など）と異なる目的で本マニュアルを使用することを禁止します。

Magnescale Co., Ltd.

Magnescale Co., Ltd.

()

Magnescale Co., Ltd.

Magnescale Co., Ltd.

The material contained in this manual consists of information that is the property of Magnescale Co., Ltd. and is intended solely for use by the purchasers of the equipment described in this manual.

Magnescale Co., Ltd. expressly prohibits the duplication of any portion of this manual or the use thereof for any purpose other than the operation or maintenance of the equipment described in this manual without the express written permission of Magnescale Co., Ltd.

Le matériel contenu dans ce manuel consiste en informations qui sont la propriété de Magnescale Co., Ltd. et sont destinées exclusivement à l'usage des acquéreurs de l'équipement décrit dans ce manuel.

Magnescale Co., Ltd. interdit formellement la copie de quelque partie que ce soit de ce manuel ou son emploi pour tout autre but que des opérations ou entretiens de l'équipement à moins d'une permission écrite de Magnescale Co., Ltd.

Die in dieser Anleitung enthaltenen Informationen sind Eigentum von Magnescale Co., Ltd. und sind ausschließlich für den Gebrauch durch den Käufer der in dieser Anleitung beschriebenen Ausrüstung bestimmt. Magnescale Co., Ltd. untersagt ausdrücklich die Vervielfältigung jeglicher Teile dieser Anleitung oder den Gebrauch derselben für irgendeinen anderen Zweck als die Bedienung oder Wartung der in dieser Anleitung beschriebenen Ausrüstung ohne ausdrückliche schriftliche Erlaubnis von Magnescale Co., Ltd.

Safety Precautions

Magnescale Co., Ltd. products are designed in full consideration of safety. However, improper handling during operation or installation is dangerous and may lead to fire, electric shock or other accidents resulting in serious injury or death. In addition, these actions may also worsen machine performance.

Therefore, be sure to observe the following safety precautions in order to prevent these types of accidents, and to read these “Safety Precautions” before operating, installing, maintaining, inspecting, repairing or otherwise working on this unit.

Warning indication meanings

The following indications are used throughout this manual, and their contents should be understood before reading the text.



Warning

Failure to observe these precautions may lead to fire, electric shock or other accidents resulting in serious injury or death.



Caution

Failure to observe these precautions may lead to electric shock or other accidents resulting in injury or damage to surrounding objects.

Symbols requiring attention



CAUTION



ELECTRICAL
SHOCK

Symbols prohibiting actions



DO NOT
DISASSEMBLE



Warning

Failing to follow the precaution items given below may lead to severe injury or death.



- Do not damage, modify, excessively bend, pull on, place heavy objects on or heat the cable, as this may damage the cable and result in fire or electric shock.



- Do not disassemble or modify the unit, as this may result in injury or electric shock. These actions may also damage the internal circuitry.



Caution

Failing to follow the precaution items given below may lead to injury or damage to surrounding objects.



- The unit does not have an explosion-proof structure. Therefore, do not use the unit in an atmosphere charged with inflammable gases as this may result in fire.

Contents

1. Operating Cautions.....	1
2. Mounting Instructions	2
3. Names of Parts.....	4
4. Specifications	5
5. Measuring Unit Output Signals.....	6
5-1. Output Signal Phase Difference.....	6
5-2. Output Signal Alarm.....	7
5-3. Receiver.....	7
6. Optional Accessories.....	8
7. Dimensions	9

General precautions

When using Magnescale Co., Ltd. products, observe the following general precautions along with those given specifically in this manual to ensure proper use of the products.

- Before and during operations, be sure to check that our products function properly.
- Provide adequate safety measures to prevent damages in case our products should develop malfunctions.
- Use outside indicated specifications or purposes and modification of our products will void any warranty of the functions and performance as specified of our products.
- When using our products in combination with other equipment, the functions and performances as noted in this manual may not be attained, depending on operating and environmental conditions.

1. Operating Cautions

- Do not use the unit in places where it may receive excessive shocks. Otherwise the inside of the unit may be damaged or the unit may become unable to produce normal output signals.
- Be sure to turn off the power before connecting or disconnecting connectors in order to prevent damage or misoperation.
- Insert the connector into the counter unit until it locks. Be sure to turn off the power switch before connecting or disconnecting the connector.
- Locate the measuring unit at least 10 cm away from a strong magnetic source. (The measuring unit must not be used in magnetic fields exceeding 5 mT.)
- Do not forcibly pull the cable for connecting or disconnecting, or it may cause breakage.
- The measuring unit is short circuited to the frame GND (ground terminal) of the counter unit by shield wire of the cable. When the measuring unit is used with another signal processing device on a machine tool, etc., be aware of the ground level.
- Do not place the measuring unit where it is exposed to splash of water or oil.
- When using a vacuum ejector or other device to operate the feeler through the air feed port, use an air-pass system such as shown in Fig. 1 to enable air driving. The optimum vacuum rate is 0.04 to 0.067 MPa.
- If the spindle ejection speed is too fast, an error may appear on the display the moment that the workpiece is touched. Excessive impact may dislodge the retainer inside the bearing, causing the measuring range to be reduced. In this case, use a speed controller as shown in Fig. 1 to adjust the spindle speed.
- The tube used for the air feed port should have an outer diameter of $\phi 4$ mm.
- Injection of air causes the spindle to perform the retraction operation.
- Use dry air for air injection.
- Calibration is recommended every year.
- This unit is equipped with an anti-dust bellows on the spindle. Organic solvents, ozone, ultraviolet rays, and other adverse conditions in the ambient atmosphere can cause rapid deterioration of the anti-dust bellows. When using in these environments, replace anti-dust bellows periodically (every six months to one year).

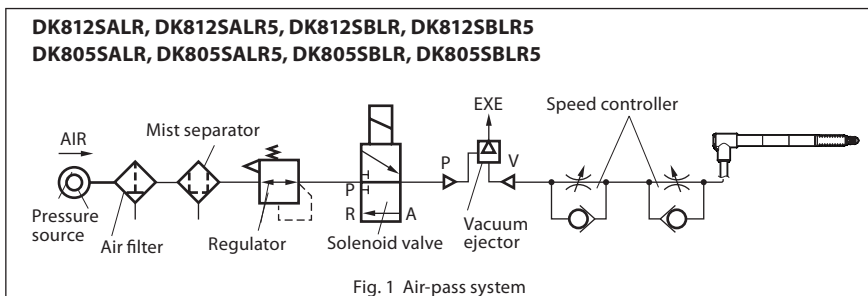

2. Mounting Instructions

- Be sure to chuck the stem of the measuring unit for mounting.
- If the measuring unit is mounted on another device, ensure that the measuring unit is free from contact with mount screws.
- When attaching and removing the feeler, use the supplied wrench. Be careful not to apply torque exceeding 0.1 N·m to the spindle. This could lead to a breakdown. Except when using a flat feeler, it is recommended to either attach the supplied spring washer (nominal size: 2.5) or use a screw lock to prevent loosening of the feeler (tightening torque reference value: 0.05–0.06 N·m) (See Fig. 2.).
- The measuring unit comprises ball bearings. Therefore, chucking the stem of the measuring unit too tightly when mounting may damage the spindle and prevent its smooth motion.
- When mounting the measuring unit on a machine by using a holder, prepare the holder with dimensions and material shown in Fig. 3, and fix the probe by fastening a screw with a special torque of 0.6 N·m.
- Attach the stem by tightening a screw into the slot as shown in Fig. 3. Never attach by screw threading in the $\phi 8$ mm hole vertical direction, pressing the stem, and then tightening with a screw. This could result in poor sliding and low precision.
- Fix the cable in a suitable position to prevent possible cable breakage. Never handle the cable by forcibly pulling or bending it. (Inside bend radius 50 mm or more)
- If the spindle is to be fixed to the machine, use coupling DZ-191 which is optionally available. Refer to the DZ-191 Instruction Manual regarding the mounting procedure.
- The measuring accuracy depends on the mounting parallelism. Adjust the squareness to the measuring surface or the parallelism to the movement to within 0.02 mm/14 mm.
- After the stem is secured, do not apply force in the rotational direction. This could cause a failure.

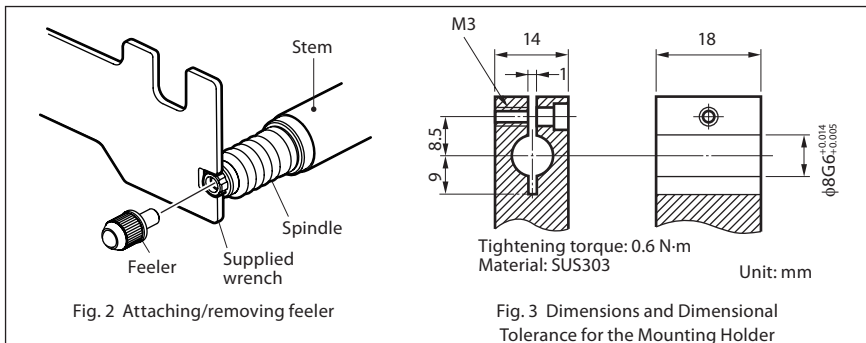

When providing an IP67 degree of protection

Use the supplied wrench (accessory) and mount the hose elbow (accessory).

Procedure

1. Remove the cap.

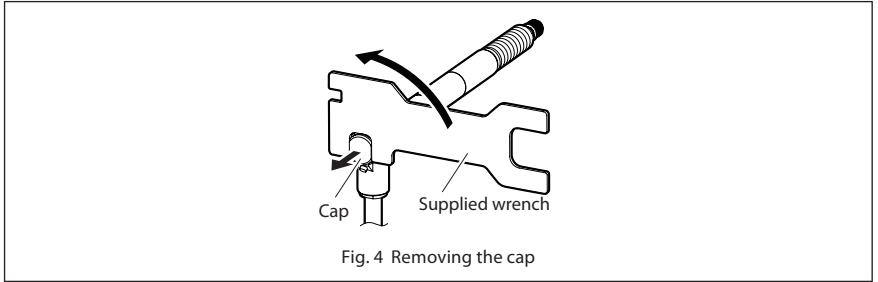

2. Attach the hose elbow.

Tighten the M5 screw by hand until the gasket contacts the wall, and then use the supplied wrench to tighten an additional approx. 90°.

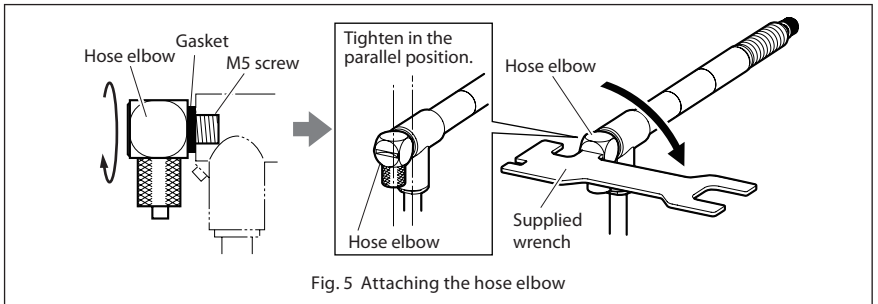

3. Attach the $\phi 4$ mm tube.

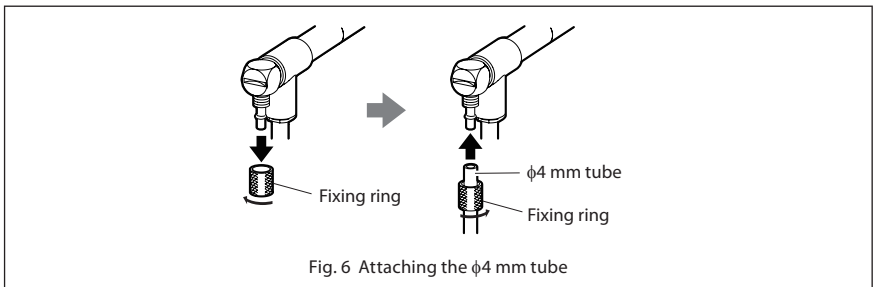

Note

Extend the tube attached to the hose elbow so that the notched part on the opposite end from the hose elbow is not exposed to water or oil.

3. Names of Parts

DK812SAR

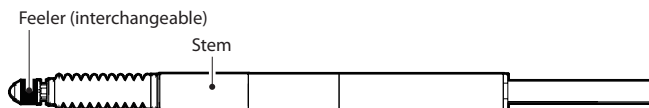

DK812SALR

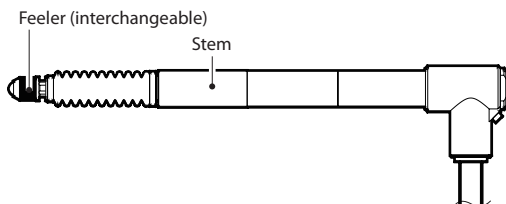

DK805SAR

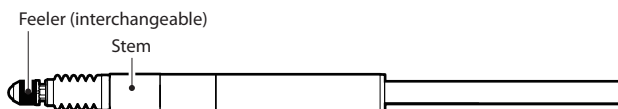

DK805SALR

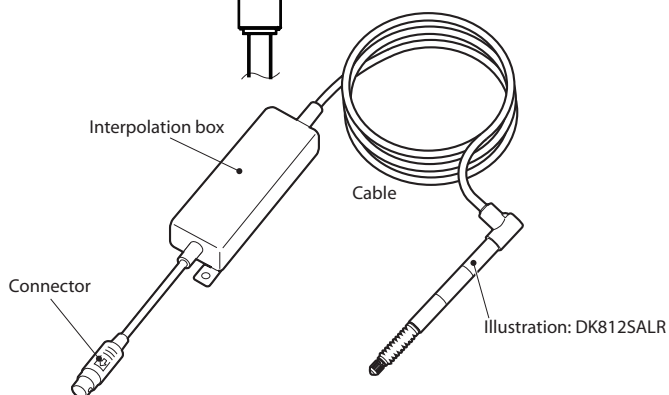
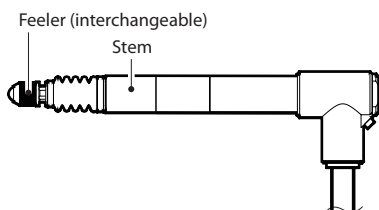

* Illustration : DK812SALR

* The air lifter cannot be attached to the DK812SAR/ DK812SAR5/DK805SAR/ DK805SAR5/DK812SBR/ DK812SBR5/DK805SBR/DK805SBR5.

4. Specifications

	High-resolution models		General-purpose resolution models	
	DK812SAR, DK812SALR, DK805SAR, DK805SALR	DK812SBR, DK812SBLR, DK805SBR, DK805SBLR	DK812SAR5, DK812SALR5, DK805SAR5, DK805SALR5	DK812SBR5, DK812SBLR5, DK805SBR5, DK805SBLR5
Output	A/B/reference point signal differential line driver output (compliant with EIA-422)			
Resolution	0.1 μm		0.5 μm	
Measuring range	DK812S: 12 mm, DK805S: 5 mm			
Accuracy (at 20°C)	1 μm p-p		1.5 μm p-p	
Measuring force (at 20°C)	DK812S	Downward: 0.6 ±0.3 N Horizontal: 0.5 ±0.3 N Upward: 0.4 ±0.3 N	DK805S	Downward: 0.45 ±0.25 N Horizontal: 0.40 ±0.25 N Upward: 0.35 ±0.25 N
Reference point	One location (at 1 mm position of spindle movement)			
Maximum response speed	80 m/min	42 m/min	250 m/min	100 m/min
Air driving	Vacuum suction (DK812SALR / DK812SALR5 / DK805SALR / DK805SALR5 / DK812SBLR / DK812SBLR5 / DK805SBLR / DK805SBLR5)			
Vibration resistance (20 to 2000 Hz)	100 m/s ²			
Impact resistance (11 ms)	1000 m/s ²			
Degree of protection ^{*1}	SAR / SBR : IP66, SALR / SBLR : IP64 (IP67 ^{*2})			
Operating temperature	0°C to 50°C			
Storage temperature	-20°C to 60°C			
Power supply voltage	DC +5 V ±5%			
Power consumption	1 W			
Cable length	2.5 m			
Diameter of stem	φ8 _{-0.009} ⁰			
Mass ^{*3}	Approx. 30 g			
Feeler	Provided with a carbide ball tip (DZ-123) Mount screw M2.5		Provided with a steel ball tip Mount screw M2.5	
Accessories	Supplied wrench, Instruction Manual, Supplement, +P M4×5 screw (2), Hose elbow (SAL and SBL types only)			
Output cable length (up to the electronic section)	22 m max.			
Life time ^{*4}	Minimum 30 million cycles without shock			

*1 Not including interpolation box and connector

*2 When using the supplied hose elbow and a φ4 mm tube

*3 Not including cable and interpolation box

*4 Depends on the evaluation test defined by Magnescale Co., Ltd.

5. Measuring Unit Output Signals

The signals output from the measuring unit are AB quadrature signals, reference point output signals in the form of differential line driver output compliant with EIA-422.

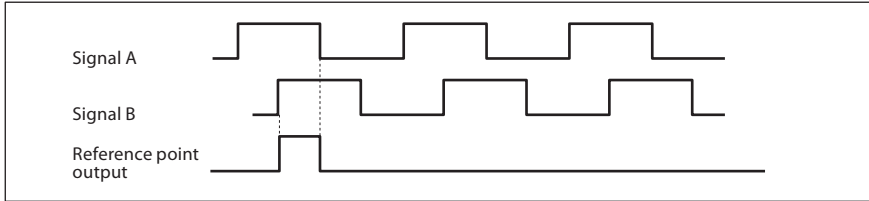

The reference point is the synchronized reference point that is at Hi level when the signal A and signal B are at the Hi level.

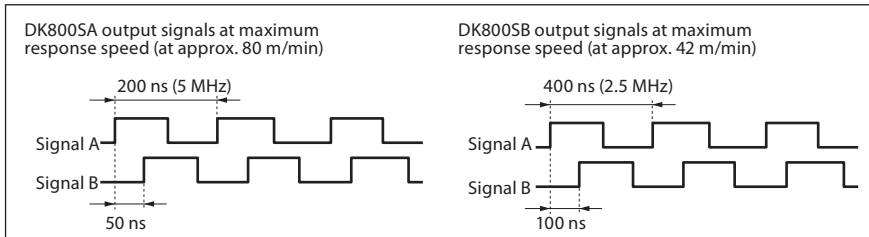

This measuring unit outputs AB quadrature signal with a maximum frequency of 5 MHz and minimum phase difference of 50 ns for the DK800SA, and a maximum frequency of 2.5 MHz and minimum phase difference of 100 ns for the DK800SB. Use a counter or controller that can process these signals.

* The minimum phase difference can be modified under special specifications. (See “5-1. Output Signal Phase Difference”)

5-1. Output Signal Phase Difference

The travel length of the measuring unit is detected every 50 ns for the DK800SA and every 100 ns for the DK800SB, and the phase difference proportional to the amount traveled is output. The phase difference changes in integer multiples of 50 ns or 100 ns. Also, the minimum phase difference for the signal A and signal B is 50 ns for the DK800SA and 100 ns for the DK800SB.

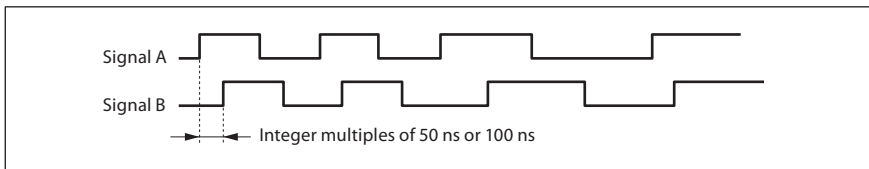

In the standard specifications, the minimum phase difference is fixed at 50 ns for the DK800SA and 100 ns for the DK800SB, but the minimum phase differences in the table below are available as custom specifications.

AB quadrature signal minimum phase difference	Signal A cycle	Counter allowable frequency	Maximum response speed		Remarks
			Resolution 0.1 μm	Resolution 0.5 μm	
50 ns	200 ns	5 MHz	80 m/min	250 m/min	DK800SA standard product
100 ns	400 ns	2.5 MHz	42 m/min	100 m/min	DK800SB standard product
300 ns	1.2 μs	833 kHz	14 m/min	33 m/min	Custom specifications
500 ns	2 μs	500 kHz	8.4 m/min	20 m/min	Custom specifications

5-2. Output Signal Alarm

If the response speed is exceeded, the AB quadrature signal output from this measuring unit changes to Hi impedance for about 400 ms to serve as an alarm.

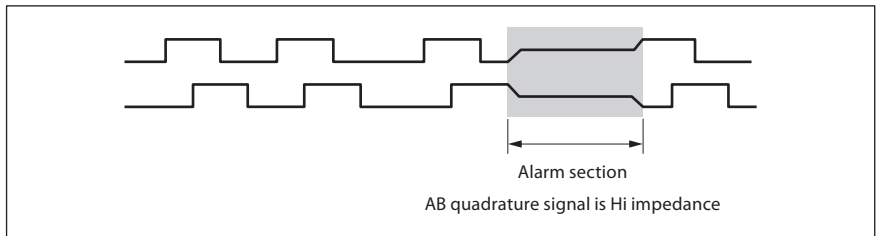

5-3. Receiver

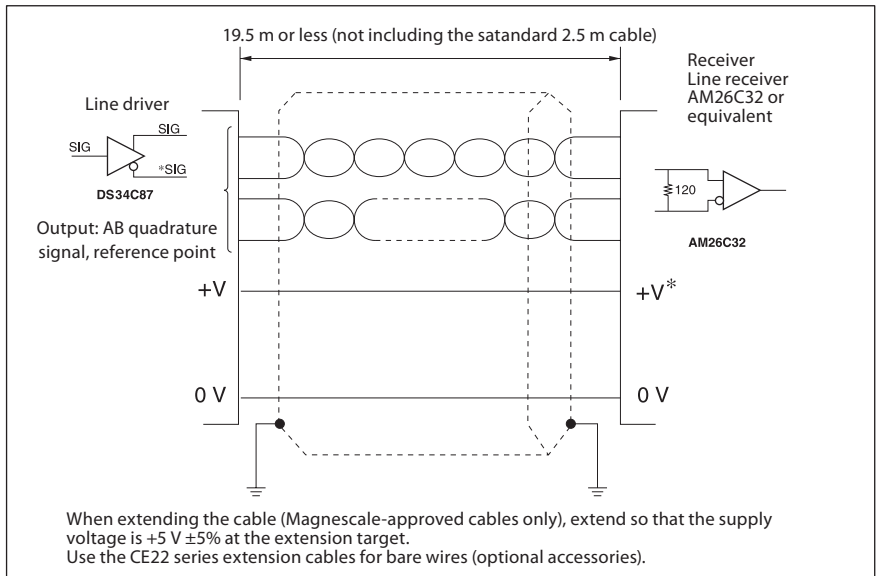

6. Optional Accessories

- Air Lifter DZ-801

The air lifter is available for manual operation of the measuring rod.

Use it in combination with DK812SALR / DK812SALR5 / DK805SALR / DK805SALR5 / DK812SBLR / DK812SBLR5 / DK805SBLR / DK805SBLR5.

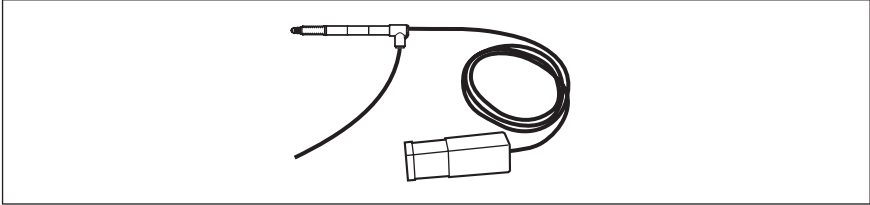

- Mounting Bush DZ-811 is optionally available to mount the measuring unit on Gauge Stand DZ-501.
- Extension cable

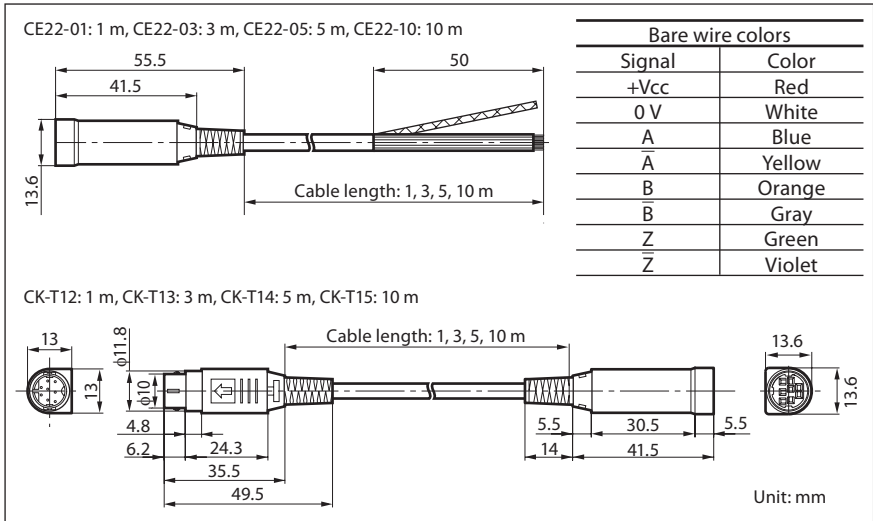

7. Dimensions

Specifications and appearances of the products are subject to change for improvement without prior notice.

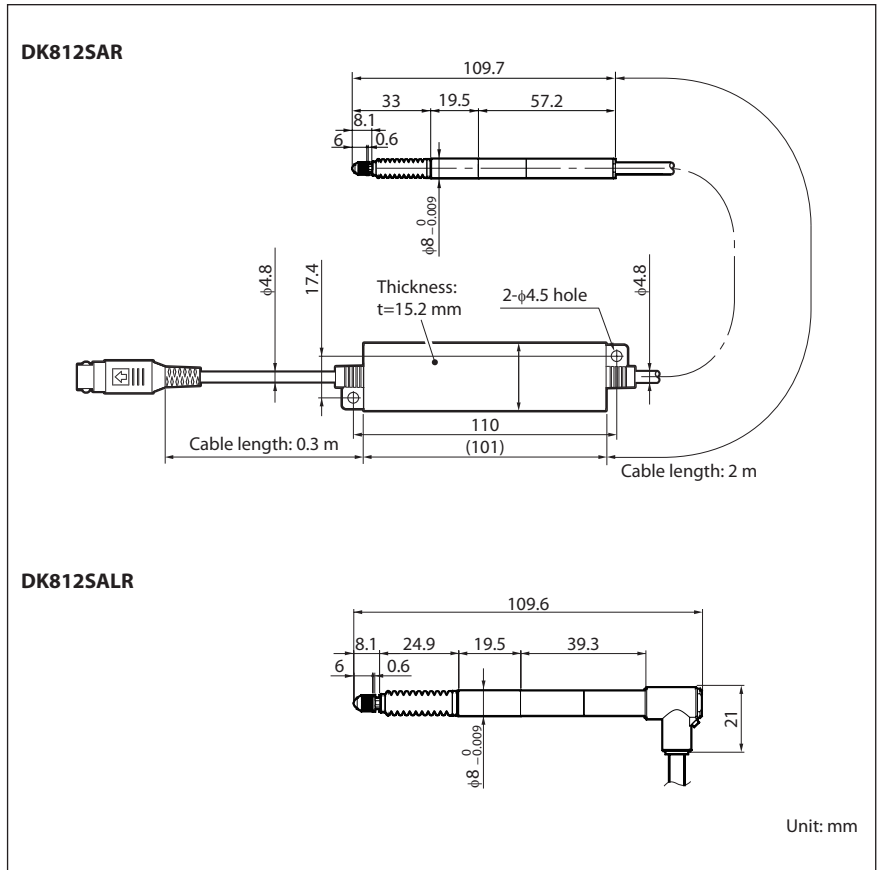

DK805SAR

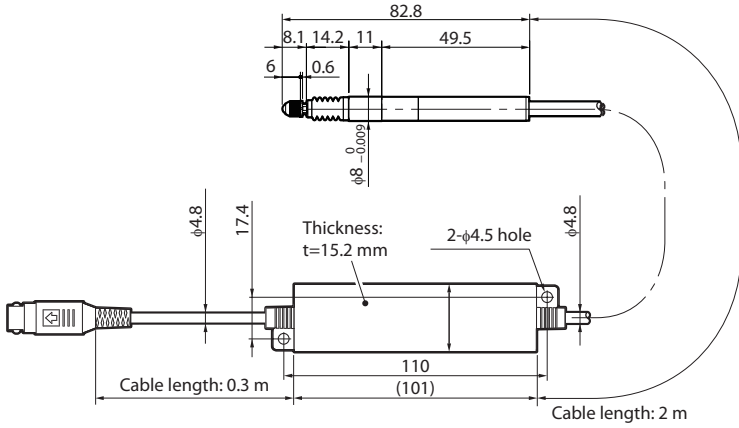

DK805SALR

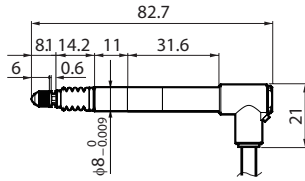

Unit: mm